

# Comparative Study of Conventional Wood-Pattern with 3D-Print ABS-Pattern to Enhance Quality of Castings

Mahantesh M Ganganallimath<sup>1,\*</sup>, K Vizayakumar<sup>2</sup>, Umesh M Bhushi<sup>3</sup>

<sup>1</sup>Basaveshwar Engineering College, Bagalkote-587102, Karnataka, India

<sup>2</sup>Retired Professor, Indian Institute of Technology (IIT), Kharagpur, India

<sup>3</sup>Higher Colleges of Technology, P.O.Box: 41012, Abu Dhabi, United Arab Emirates (UAE)

\*Author to whom correspondence should be addressed:

E-mail:mmgmth@gmail.com

(Received February 1, 2022; Revised May 14, 2023; accepted May 14, 2023).

**Abstract:** Traditional foundry methods have a long lead-time and expensive manufacturing costs. Using wood as a pattern material makes it challenging to create intricate and thin curved patterns. For better-quality products, metal patterns can take the place of wood ones, but the price would go up. This work uses an ABS (Acrylonitrile Butadiene Styrene) pattern in place of the wood pattern. Making ABS pattern involves the use of 3D printing technologies. ABS-patterns are made to be simple to create complex patterns with enhanced yield, pattern longevity, resistance to ramming forces, chemical reaction resistance, exact geometrical shapes, surface texture, and dimensional precision, as well as shorter lead times and lower lead costs. From the study, it is derived that 3D printing and ABS cast patterns would help the casting industry to face the present challenges of cost and quality.

Keywords: ABS-Pattern, Castings, Foundry, Wood-Pattern, 3D Printing, Quality Improvement

## 1. Introduction

3D Printing is also known as Rapid Prototyping (RP) or Additive Manufacturing (AM). This process is known for adding or joining materials (metals or plastics) to make a specific product from software-generated 3D model data. The 3D model is converted into STL binary file format by using the conversion software available for the machine. Every 3Dprinting machine has its conversion software depending on the company. It works on the principle of the additive method of manufacturing.

Today 3Dprinting and additive manufacturing are the common terms used in the consumer market and manufacturing industry, respectively. The 3D-Printing process uses metal powders or plastic filament and is an up-growing system in the manufacturing family. Selecting the fabrication material depends on the properties and dimensional requirements of the product.

The 3Dprinting process is becoming suitable for producing not only prototypes as before but also complex shapes for end-use parts with high surface finish and dimensional accuracy. Patterns play a vital role in the casting industry. The quality of casting depends on the quality of pattern in most cases. Different materials are used to prepare patterns, namely aluminum, wood, ferrous metals. The pattern material selection is the very important step in casting.

It depends on two criteria; one is the quantity to be expected to produce from a single pattern and another is customer requirements with specifications mentioned in the component.

### 1.1 Observations from literature survey

The use of 3Dprinting techniques and FDM printed patterns in a foundry can eliminate material wastage and reduce the lead-time and cost<sup>1</sup>. FDM technique also has the capacity to produce patterns of required surface quality and 900 orientations are better compared to orientations<sup>2</sup>. Using 3D printing technology problems of traditional methods of pattern making can be resolved for sand casting<sup>3</sup>.

In addition, it reduces lead-time and helps to achieve dimensional accuracy<sup>4</sup>. ABS patterns are found stronger because of its rigidity to withstand the ramming forces. Moisture can affect the properties of materials like wood which reduces the quality, accuracy and strength of the parts produced but moisture has no effects on ABS-patterns<sup>5</sup>. 3D-printing technology is not ideal for mass production of components but can be used to produce short-series components<sup>6</sup>. Process parameters like layer thickness, raster angle, building orientation, printing speed and extrusion temperatures have a major impact on the mechanical properties of the patterns<sup>7</sup>.

The quality of the casting depends on the mold and patterns used in the casting process<sup>8)</sup>. Conventional methods of manufacturing using subtractive manufacturing technology takes longer time for tool preparation with cost<sup>9)</sup>. Rapid casting technologies based on 3D printing, are effective for the production of cast technological prototypes in very short times with dimensional tolerances that are completely consistent with metal casting processes<sup>10)</sup>.

To enhance the general qualities of parts made utilizing rapid prototyping techniques, are being developed<sup>11)</sup>. Costs will probably decrease as 3D printing technology advances, and speed will unavoidably rise. Furthermore, quality is probably going to get better as more materials are employed<sup>12)</sup>. The obstacles to 3D Printing adoption in current foundry operations are: capital equipment costs, transportation of moulds and cores, accessibility and limited understanding of 3D Printing, lengthy lead times to acquire 3DSP moulds and cores<sup>13)</sup>. The production of customized goods in small quantities using traditional manufacturing involves high costs, extended processing times, and significant material waste. As a result, the idea of additive manufacturing (AM) is created, with fused deposition modelling (FDM) leading research efforts<sup>14)</sup>. The best elements must be obtained, such as build orientation, layer thickness, nozzle diameter, infill pattern, and bed temperature<sup>15)</sup>.

Using 3D printing technology, you may speed up manufacturing while minimizing errors and abnormalities<sup>16)</sup>. One of the biggest issues that organizations will face in the future is how to develop a strong culture that prioritizes quality, thus managers must look for innovative ways to manage quality. In this case, they should investigate how their organizations might do this<sup>17)</sup>. One of the many additive manufacturing processes that may create components out of multiple materials is fused deposition modelling (FDM). However, the FDM component's tensile strength is innately low, making it challenging to employ for engineering applications<sup>18)</sup>. Sales of associated equipment have greatly expanded since 3D printing came to the fore as a very viable technology in terms of cost and speed<sup>19)</sup>. In general, the technology is still experimental, but it is quickly developing into a reliable and practical manufacturing platform. The economic, manufacturing, and domestic spheres will undergo a major upheaval once enterprise 3D printing is fully established<sup>20)</sup>.

Various types of polymers, including thermoplastics, thermosets, elastomers, hydrogels, functional polymers, polymer blends, composites, and biological systems, are employed in additive manufacturing (AM)<sup>21)</sup>. Since 3D printed objects are frequently customized and not meant for mass production, it can be challenging to establish tolerance profiles to evaluate manufacturing quality<sup>22)</sup>. Designing the present breed is incredibly difficult and complex. The creation, advancement, and application of novel and creative manufacturing techniques are thus

strongly encouraged<sup>23)</sup>. Wear characteristics in the 3D cast group were significantly better than those in the fiberglass cast group, perhaps as a result of the 3D casts' more streamlined shape and lighter weight construction<sup>24)</sup>. The design of goods, assemblies, and parts, such as castings, patterns, cores, moulds, and shells in the manufacture of castings, will be revolutionized by 3D printing, which is most crucially not merely a manufacturing technique<sup>25)</sup>.

From the literature survey, it is found that much of the research work has been carried out on 3D-Printing technology and Fused Deposition Modeling(FDM) process is popularly applied to prototype making for destructive testing, visual models and manufacturing applications. Some researchers are trying to replace pattern materials like wood, wax, metal alloys with ABS Resins, and a mix of ABS and Resins.

In this work, it is planned to use 3D-Printing technology and FDM process to produce a casting pattern from ABS material. The cast part is produced using an ABS pattern and then compared with the parts that are produced from a wood pattern.

## 2. Methodology

ABS pattern is produced through 3D-Printing and consists of the following steps:

1. Preparation of 2D-Drawing
2. Preparation of 3D-Model
3. Machine Specifications
4. Raw Material and Support Material
5. Convert 3D model into STL file
6. Configure Modeler
7. Build the component

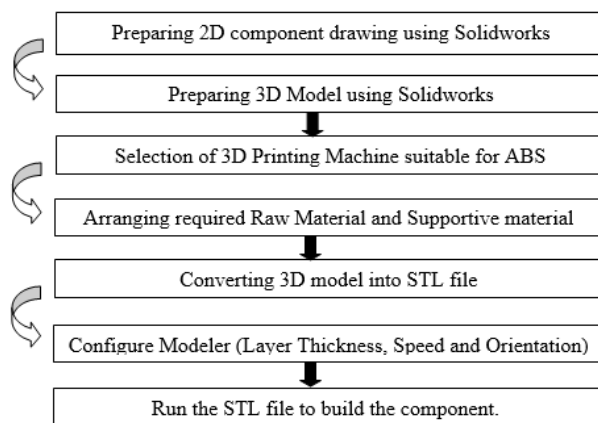

### 2.1 Preparation of 2D-Drawing and 3D-Model

A drawing used in industry for manufacturing the component is termed a component drawing. A component drawing contains all the details of the product like basic dimensions, tolerances, material, operations, tools, and cross-sections. It furnishes every dimension, special finishing operations, limits, and processes such as heat treatment, grinding and material to be used.

The software is used to create a 3D solid model to build on the relationship that will allow the parameters to automatically calculate based on the value of another parameter. 2D drawings can be directly imported to the sketch in a part document for converting into a 3D model. To create a base feature from a 2D drawing, the extract sketches must specify for the appropriate view. Solidworks creates unique solid primitives by using existing 2D objects. It also helps to build any complex model within a short time with accurate model calculations and provides different views, which include auxiliary, orthographic, isometric, sectional, and detailed views.

Solid works software is a fully associative system and easily available in the market at a low cost. Associatively also allows us to apply the mathematical expressions, parametric constraints to the surfaces. In the development process, a small change in the design model can be propagated throughout the system. Solidworks workspaces were sets of menus, toolbars and windows that are grouped and organized such that anyone can work in a custom and task-oriented drawing environment.

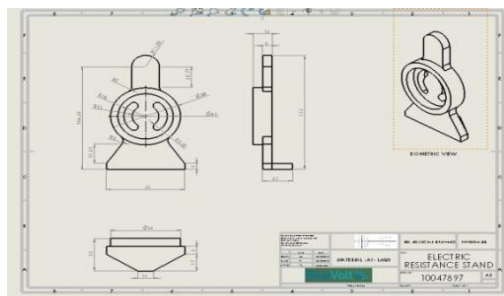

Fig.1:2D-Component Drawing

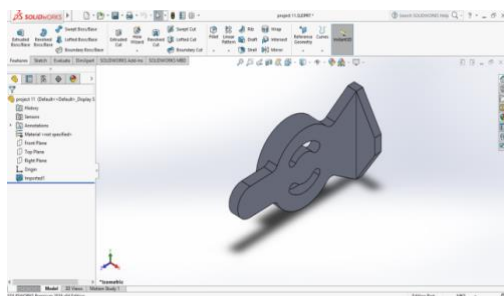

Fig.2:3D-Model of the Component

**2.2 Machine Specifications**

The Fortus-250 machine (refer Table 1. For specifications) can produce prototypes and end-use parts utilizing ABS material. Fortus-250 machine features three-layer thicknesses of 0.178, 0.254, 0.330 mm. A CAD files to be in STL format. The software sections the design into layers and creates tool paths for the part and its disposable support structures. Build trays or sheets need routine replacement as do extrusion nozzles. The material cost per cubic inch of part is less with FDM because it needs only minimal support material.

Table 1. Specifications of 3D-Printing Machine

FDM Machine	FORTUS 250mc
System Type	Fortus 250mc
Serial Number	P16017
System Software	Version 10.4 build 3978
Build Platform Dimensions	254x254x305
Slice Software	INSIGHT
Layer Height (min)	178 microns
Layer Height (max)	330 microns

**2.3 Raw Material and Support Material**

**Modeler Material: ABS P430**

ABS P430 offers specialized properties namely toughness, ductility, translucence, and biocompatibility. This is very popular due to its strong binding properties and low production cost. ABS is a very common thermoplastic polymer used in the fused deposition modeling process. ABS has a Glass transition temperature close to 105 °C. Due to the amorphous composition, the material has no true melting point. The ABS material is stronger than pure polystyrene due to nitrile groups which attract each other and bind the chains closely. Styrene provides an impervious and shiny surface to the plastic and butadiene make the composite tough enough at a lower temperature. ABS is good shock absorbance material.



Fig.3:ABS Cartridge



Fig.4:ABS Cable



Fig.5:3

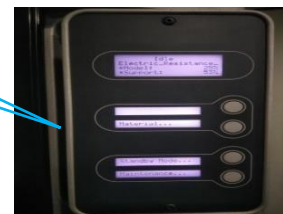

Fig.6:Display Panel

**Support Material: ABS SR30**

Stratasys software automatically creates any required support structure to build a specific part. This method is ideal for the parts to be built with a simple support structure. The use of hand tools can greatly bring down the amount of time spent on the removal of support material from the finished parts. The wavy wash system sets and maintains water temperature automatically within a clean tank. But water temperatures between 70 to 75°C (158 to 167° F) are highly effective for dissolving the support materials.

### 2.4 Convert 3D-Model into STL-File

Once the 3D model is developed, it is then necessary to convert it into an STL file format. To carry out the project we have chosen the Stratasys machine and INSIGHT software is used to convert the 3D model into an STL binary file, which covers all the surfaces of the object by triangular surfaces. Support structures are water-soluble which can be easily separable from the main object after finishing the printing process. It takes around 15-20 minutes to convert the 3D model into an STL file format. Material volume, surface area, part footprint, and configuration can all add hours to the build time. To measure speed, one must clock the entire process, starting with the moment an STL file starts functioning and completes printing the part, and is stopped till the part is ready for use. The next action is to prepare to slice and creating the tool paths which takes 20-25 seconds approximately depending on the volume of the object. Surface quality and its aesthetic look are considered before selecting the slice thickness.

### 2.5 Configure Process Parameters

The configuration chooses the type of the modeler, model and support materials, extrusions tip size, and the slice height to be used in the current job. Once the parameters are selected (refer Table 2.); the next step is to select the part interior Style. There are two types of interior styles. One is solid normal is a standard and the other is sparse which will build the part with hollow, honeycomb type interior and solid outer wall. Considering 0.254mm as slice height the estimated time to print the model is 2hours and 33 minutes. Support style is always the sparse supports in which supports are used with default waterworks support materials as well as those can also be chosen along with manual supports to decrease build time while building larger parts without tiny features. Surface finishing improves with decreasing the slice height.

Table 2. Process Parameters

Modeler	Type of modeler to be used	Fortus 250mc
Model Material	Type of material to build the part.	ABS P430
Support Material	Type of material to build the supports.	ABS SR30
Model Tip	Size of the model material extrusion tip.	T14
Support Tip	Size of the support material extrusion tip.	T16
Slice Height	Layer thickness	0.254mm

### 2.6 Build the Component

Check the required space available on the plate before inserting it into the machine, once confirmed open the door and insert the platform plate into the machine and

lock it properly before calibrating and setting the temperature range for printing the part. Check the model and support material availability of the cartridge. Let the machine warm up to a suitable temperature to make a strong bonding between the layers. The ABS material pallets were dried to remove the moisture content, which disturbs the surface accuracy and finishing of the object.

Virtual blueprints are sliced into digital cross-sections to be used as guidelines for printing, these cross-sections are joined together to create the final object. The nozzle temperature was set to 240°C and the heating bed temperature of 75°C. The layer thickness and printing speed were maintained at 0.254mm and 40mm/min respectively. Once the printing operation is over, the pattern is removed from the machine and kept at room temperature for 2-3minutes. The support structures are attached to the modular in bottom section.

After printing the pattern supports structures are removed by hand and the material, which is difficult to remove manually, is kept in water for some time and then removed. In some cases sanding, buffing or painting may be applied to obtain the required finishing.

### 2.7 Producing Cast-parts by Sand Casting

The procedure for making wood pattern is as follows:

1. Marking on wood sheet as per the specifications
2. Cutting the wood sheet by using band saw machine
3. Grinding cut parts to remove sharp edges.
4. Drill wherever necessary
5. Checking for dimensions
6. Assembling cut pieces by applying wood glue
7. Apply gap filling paint on corners
8. Surface finish by using sandpaper

The focus is on small-and-medium enterprises (SME), foundries that manufacture the sand castings. The company selected for the study is pioneer in the category of casting such as Sand mold casting, Aluminum Die casting, Pressure Die casting, manufacturers in Kolhapur. Organization is having sufficient infrastructure and well equipped with necessary tools, machine equipment and other facilities for manufacturing sand castings. Plant size is about 7500sq.ft. The production units are flawlessly finished and equipped with all desired machines and equipment. Various departments, which include production, quality control, sales, and marketing departments, function parallel. The organization has a team of skilled workers. Company employees are highly experienced and qualified with 6.0 crore rupees turnover approximately. Team members in the company help to achieve a miraculous presence in the market. They help their clients by offering them supreme quality products range. They accomplish their work with their great efficiency and knowledge. With their support, organization has established a strong foothold in the industrial hub.

Products are reliable and durable for long time and manufactured from the high-grade raw material. Before delivery, they stringently inspect quality of our entire products and receive positive feedback from their valuable clients.

Following are the steps followed for producing castings through the ABS pattern.

1. Arranging Cope and Drag
2. Sand Preparation
3. Mold cavity from Wood-Pattern
4. Melting the metal
5. Pouring molten metal into the cavity
6. Removing casting from the mold
7. Cleaning and finishing

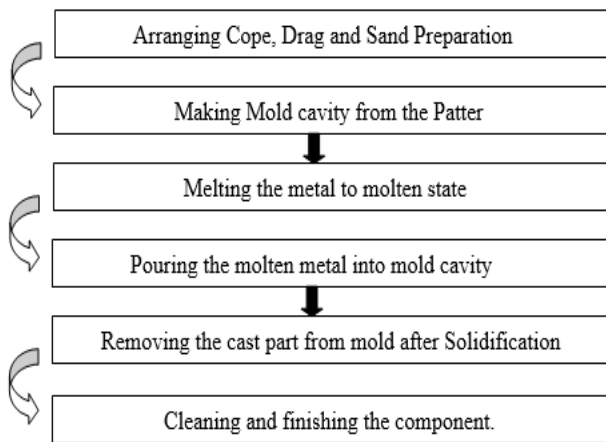

The sand used for mold making varies from well rounded to rounded, semi-rounded, sub-angular, angular, and very angular. The core box is placed on the bed and simultaneously pattern kept in a mold to form the cavity. The mixture of sand is added to the box, Squeezing and ramming operations are carried out around a pattern to get the exact shape of it. A small cavity is formed with funnel-shaped at the top of the mold is known as “pouring cup” in which molten metal is poured and then it flows to the sprue. Gate is the actual entry point through which the molten metal enters the cavity.

The liquid metal to be poured into the mold cavity at a uniform rate and then allowed to solidify inside the mold for 25-30 minutes at room temperature. The casting is removed from the mold by a shakeout process in which molds are vibrated. After cooling the component for some time and dipped in water; the mold was broken down by applying external forces on it. Cleaning generally referred to removing all the materials which are not a part of the final casting. Cleaning is done to remove all the gating systems from casting. Remove any residual mold, core, and sand that remain over the piece after it is freed from the mold. Trimming removes all superfluous metal with the help of a band saw machine. Buffing operation is carried to remove the sharp edges and clean the surface of casting to improve the appearance.



Fig.7: Mold Cavity



Fig.8: Cast Part

Finally, the casting is being inspected for defects and any adherence to the quality standards. This inspection includes nondestructive testing for the determination of the part which correctly performs its functions.

### 3. Results and Discussion

The wood-pattern is made using machining operations and manually both. The plywood sheet is selected based on the type of wood-pattern shape and size. The thickness of the plywood sheet depends on the thickness of the pattern required. High-skilled labor is required for manual operations. The accuracy of the pattern depends on the skill of the labor. Whereas ABS pattern making depends on the 3D model and machine operator. Thus, the difference in pattern-making methods for wood and ABS brings the difference in the total cost of pattern making. For making a wood pattern, the profile templates of the part are prepared in sheet metal with thicknesses between 2.0-3.0mm. With these profile templates, the layout marking is a dome on the plywood sheet of thickness 8.0 mm and then the cutting operation along the profile boundary is carried to cut out the pieces of shapes that are required. The cutout pieces are joined to form the pattern. For making ABS pattern, first 2D drawing of the component is done and then 3D-model is built from the 2D sketch using CAD software. The 3D model is converted into an STL file using INSIGHT software. The pattern needs sharp corners to be maintained as the cast product produced would function better in their assembly with sharp corners. Maintaining round corners would add one machining operation extra and parallel the product cost would increase.

Table 3. Tools and Equipment used to make wood-pattern

Teak Wood	Worktable	Vernier Protractor
Turning Lathe	Chisel	Grinding Machine
Hand Saw	Emery Paper	Drilling Machine
Wood Glue	Filler Paint	Square-form Mallet
Varnish	Inside Calliper	Band Saw Machine
Hammers	Outside Calliper	Micrometer Screw Gauge
Files	Vernier Calliper	-

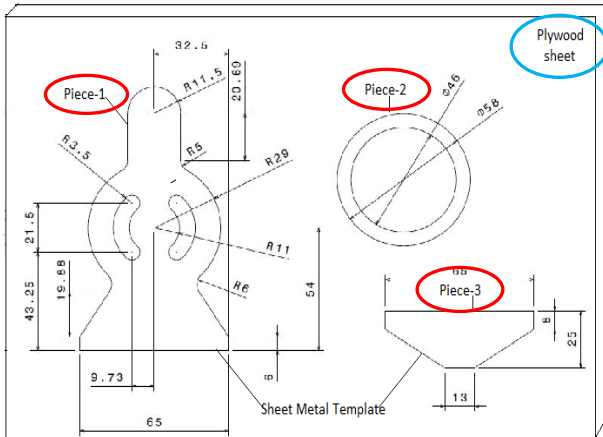

**Fig.9:Sharp Corners in ABS-Pattern**

**Cost of Wood-Pattern:**

- = Raw Material Cost + Conversion Cost
- = (120\*50\*10mm) +(Labor cost +Equipment cost +Other/overhead costs)
- = Rs. 310.00 + Rs. 730.00
- = Rs. 1040.00

**Cost of ABS-Pattern:**

- = Raw Material Cost + Conversion Cost
- = (Ø1.2xLmm) + (Labor cost +Machine cost +Other/overhead costs)
- = Rs. 490.00 + Rs. 400.00
- = Rs. 890.00

**Time taken to make Wood-pattern (hours):**

- = Profile Templates + Cutting Operations + Finishing Operations
- = 4.0 + 2.0 + 5.0
- = 11.0 Hours

**Time taken to make ABS-pattern (hours):**

- = 2D Drawing + 3D-Modeling + STL File + 3D-Printing
- = 1.5 + 1.0 + 0.5 + 2.0
- = 5.0 Hours

Novel techniques to print metal alloys and composites are examined to increase the productivity of the Fused Deposition Modeling (FDM) process<sup>15)</sup>. The edges in the ABS pattern were able to be achieved by a 3D printing method and this reduced one complete machining operation. The machining operation in the parts produced by wood pattern was to maintain sharp corners and it the major requirement by the customer.

The surface texture of cast-parts made from wood-pattern and ABS-pattern were measured using EQ-SRT-6100 surface roughness tester and the observed values are 7.11µm and 1.99µm respectively.

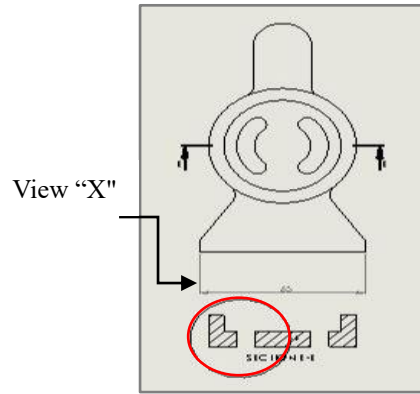

**Fig.10:Sharp Corners in ABS-Pattern**

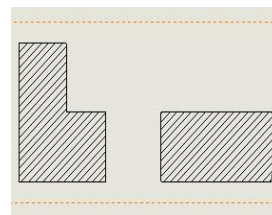

**Fig.11:Enlarged View of "X"**

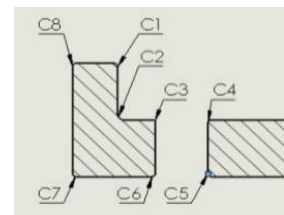

**Fig.12:Position of Corners**

It is difficult to maintain sharp corners in wood patterns and hence the edges of the pattern geometry were maintained as round corners. The added advantage of the round corners make the flow of molten metal in the mold cavity easy.

The surface texture of castings produced by wood-pattern and ABS-pattern were measured using EQ-SRT-6100 surface roughness tester and found to be 7.11 µm and 1.99 µm respectively.



**Fig.13:Cast part from Wood-pattern (7.11µm)**



**Fig.14:Cast part from ABS-Pattern(1.99µm)**

The dimensions of the aluminum product (sand cast) made by using wood patterns and ABS are measured. The observations are made on the dimensional deviations of the part, the part cast by ABS pattern is precise than the part cast by wooden pattern. Due to the high density and rigidity pattern fabricated by ABS has more life than the pattern fabricated by wood.

The life of the ABS pattern is 260-280 casts per pattern and wood patterns can produce only 40-60 casts per pattern.The tooling time and cost involved in the manufacturing of low-volume customized products are reduced by the FDM-based rapid tooling technique<sup>14)</sup>.

## 4. Conclusion

The time taken and cost incurred to make wood patterns for a casting process are key factors of manufacturing technology to comply with the customers demand. ABS Pattern and 3D printing technology are considered to overcome the problems faced by small and medium foundries in terms of lead-time, cost and quality of the castings.

Table 4. Comparison of Wood-Pattern and ABS-Pattern

Parameter	Wood Pattern	ABS Pattern
Time to Make	11.0 Hours	5.0 Hours
Cost of Pattern	Rs. 1040.00	Rs. 890.00
Surface finish	7.1 $\mu\text{m}$	1.9 $\mu\text{m}$
Pattern Life	40-50 Casts	260-280 Casts
Dimensional Accuracy	Low	High
Sharp Corners	Difficult to make	Easy to make
Operator skill required	High	Low
Computer knowledge	Not Required	Required
Investments	Low	High
Machining operations	Required	Not Required



Fig.15: Wood-Patterns and Part from Wood-Pattern



Fig.16: ABS-Patterns and Part from ABS-Pattern

The application of 3D printing technology benefits in making precision patterns required for foundry practices. The exploratory result shows better quality of the cast part at lower cost and improved lead-time.

The lead-time of the wood pattern will increase with

respect to complexity. The ABS pattern made by FDM process overcomes all the problems faced during conventional process. The alternate option to the wooden pattern must be abrasion-resistant, be able to withstand ramming forces and chemicals in the sand. ABS meets these requirements effectively. The surface roughness of the cast part obtained from the ABS pattern is much better than the surface finish of the cast obtained from a wooden pattern. From the above results, it is observed that, 55% reduction in the lead-time of the ABS pattern compared to the wood pattern.

**Future Scope:** Instead of taking only ABS as raw material, the mix of ABS with polyurethane resin (Axson F19) may be tested as the scope of future work expecting that there would be an improvement in the strength of the pattern because of predictable increase in the hardness and abrasion resistance of the pattern. An attempt can be made as future scope to study the effect of grain structure by varying layer thickness, printing speed, and orientation of the part as process parameters.

## References

- 1) Patil, R. "Development of Complex Patterns: Scope and Benefits of Rapid Prototyping in Foundries", *Ssrn*, 1, 68–72, (2012).
- 2) Hafsa, M.N.; Kassim, N.; Ismail, S.; Kamaruddin, S.A.; Hafeez, T.M.; Ibrahim, M. "Study on Surface Roughness Quality of FDM and MJM Additive Manufacturing Model for Implementation as Investment Casting Sacrificial Pattern", 5, 25–34, (2018).
- 3) Anakhu, P.I.; Bolu, C.A.; Abioye, A.A.; Azeta, J. Fused Deposition Modeling Printed Patterns for Sand Casting in a Nigerian Foundry: A Review. *Ijaer*, 13, 5113–5119 (2018).
- 4) R.R.M. Development of Casting Pattern Using Rapid Prototyping. *Int. J. Res. Eng. Technol.*, 03, 277–280 (2015).
- 5) Mendonsa, C.; Shenoy, V.D. Additive Manufacturing Technique in Pattern making for Metal Casting using Fused Filament Fabrication Printer. *J. Basic Appl. Eng. Res. Print*, 1, 2350–77 (2014).
- 6) Sathish, T.; Vijayakumar, M.D.; Krishnan Ayyangar, A. Design and Fabrication of Industrial Components Using 3D Printing. *Mater. Today Proc.*, 5, 14489–14498 (2018).
- 7) Huang, B.; Meng, S.; He, H.; Jia, Y.; Xu, Y.; Huang, H. Study of processing parameters in fused deposition modeling based on mechanical properties of acrylonitrile-butadiene-styrene filament. *Polym. Eng. Sci.*, 59, 120–128 (2019).
- 8) S. Maidinet al.; Investigation of optimum gating system design of fused deposition modelling pattern for sand casting. *Journal of Mechanical Engineering and Sciences.*, ISSN: 2289-4659 (2017).

- 9) Kuczko, W.; Wichniarek, R.; Górski, F.; Buń, P.; Zawadzki, P. Application of Additively Manufactured Polymer Composite Prototypes in Foundry. *Adv. Sci. Technol. Res. J.*, 9, 20–27 (2015).
- 10) Selvamani, S.K.; Samykano, M.; Subramaniam, S.R.; Ngui, W.K.; Kadirgama, K.; Sudhakar, K.; Idris, M.S. "Preliminary investigation of acrylonitrile butadiene styrene (ABS) properties", *AIP Conf. Proc.*, 2059 (2019).
- 11) Guan, H.W.; Savalani, M.M.; Gibson, I.; Diegel, O. "Influence of Fill Gap on Flexural Strength of Parts Fabricated by Curved Layer Fused Deposition Modeling", *Procedia Technol.*, 20, 243–248 (2015).
- 12) Tammy McCausland, 3D Printing's Time to Shine, *Research-Technology Management*, 63:5, 62-65(2020).
- 13) Lynch, P., Hasbrouck, C.R., Wilck, J., Kay, M. and Manogharan, G., "Challenges and opportunities to integrate the oldest and newest manufacturing processes: metal casting and additive manufacturing", *Rapid Prototyping Journal*, Vol. 26 No. 6, pp. 1145-1154(2020).
- 14) Sathies T., Senthil P., Anoop M.S., "A review on advancements in applications of fused deposition modelling process", *Rapid Prototyping Journal*, Vol. 26 No. 4, pp. 669-687(2020).
- 15) LaleganiDezaki, M., MohdAriffin, M.K.A. and Hata mi, S., "An overview of fused deposition modelling (FDM): research, development and process optimisation", *Rapid Prototyping Journal*, Vol. 27 No. 3, pp. 562-582(2021).
- 16) Muhammad Nazmi Hadi Roslan, Nor Atiqah Zolpakar, Normah Mohd-Ghazali and Fatimah Al-Zahrah Mohd Saat, "Analysis of 3D Printed Stack in Thermoacoustic Cooling", *EVERGREEN Joint Journal of Novel Carbon Resource Sciences & Green Asia Strategy*, Vol. 08, Issue 01, pp131-137, (2021). <https://doi.org/10.5109/4372269>
- 17) Rully Andhika1, Yusuf Latief, "Conceptual Framework of Development of Quality Culture in Indonesian Construction Company", *EVERGREEN Joint Journal of Novel Carbon Resource Sciences & Green Asia Strategy*, Vol. 07, Issue 01, pp144-149, (2020), <https://doi.org/10.5109/2740971>
- 18) Nagendra Kumar Maurya, Vikas Rastogi, Pushpendra Singh, "Experimental and Computational Investigation on Mechanical Properties of Reinforced Additive Manufactured Component", *EVERGREEN Joint Journal of Novel Carbon Resource Sciences & Green Asia Strategy*, Vol. 06, Issue 03, pp207-214, (2019). <https://doi.org/10.5109/2349296>
- 19) Simranpreet Singh Gill, M. Kaplas, Comparative Study of 3D Printing Technologies for Rapid Casting of Aluminium Alloy, *Materials and Manufacturing Processes*, Volume 24, Issue 12, Pages 1405-1411, (2009).
- 20) J. Dale Prince, 3D Printing: An Industrial Revolution, *Journal of Electronic Resources in Medical Libraries*, Volume 11, Issue 1, Pages 39-45, (2014).
- 21) Samuel Clark Ligon, Robert Liska, Jürgen Stampfl, Matthias Gurr, and Rolf Mühlaupt, Polymers for 3D Printing and Customized Additive Manufacturing, *Chem. Rev.*, 117, 15, 10212–10290, July 30, 2017.
- 22) Hao Wang, Qiong Zhang, Kaibo Wang & Xinwei Deng, A statistics-guided approach to dimensional quality characterization of free-form surfaces with an application to 3D printing, *Quality Engineering*, Volume 32, Issue 4, Pages 721-739, (2020).
- 23) Osama Abdulhameed, Abdulrahman Al-Ahmari, Wadea Ameen and Syed Hammad Mian, Additive manufacturing: Challenges, trends, and applications, *Advances in Mechanical Engineering*, Vol. 11(2) 1–27, (2019).
- 24) Jack Graham, Mark Wang, Kaela Frizzell, Cynthia Watkins, Pedro Beredjiklian, and Michael Rivlin, Conventional vs 3-Dimensional Printed Cast Wear Comfort, *American Association for Hand Surgery, HAND*, Vol 15, Issue 3, pp 1-5, (2020).
- 25) Jin-wu Kang and Qiang-xian Ma, The role and impact of 3D printing technologies in casting, *China Foundry: Special Report Vol.14 No.3 May*, 157-168, (2017).